

(No Model.)

4 Sheets—Sheet 1.

M. D. LEAR.
CLOTHES PIN LATHE.

No. 490,206.

Patented Jan. 17, 1893.

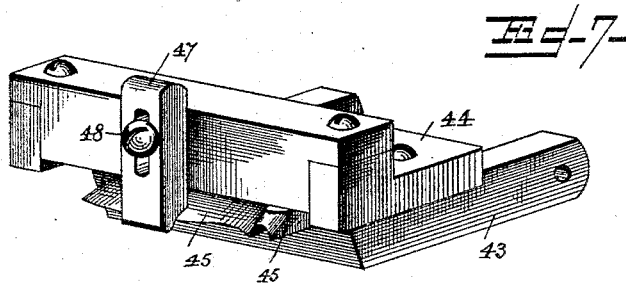
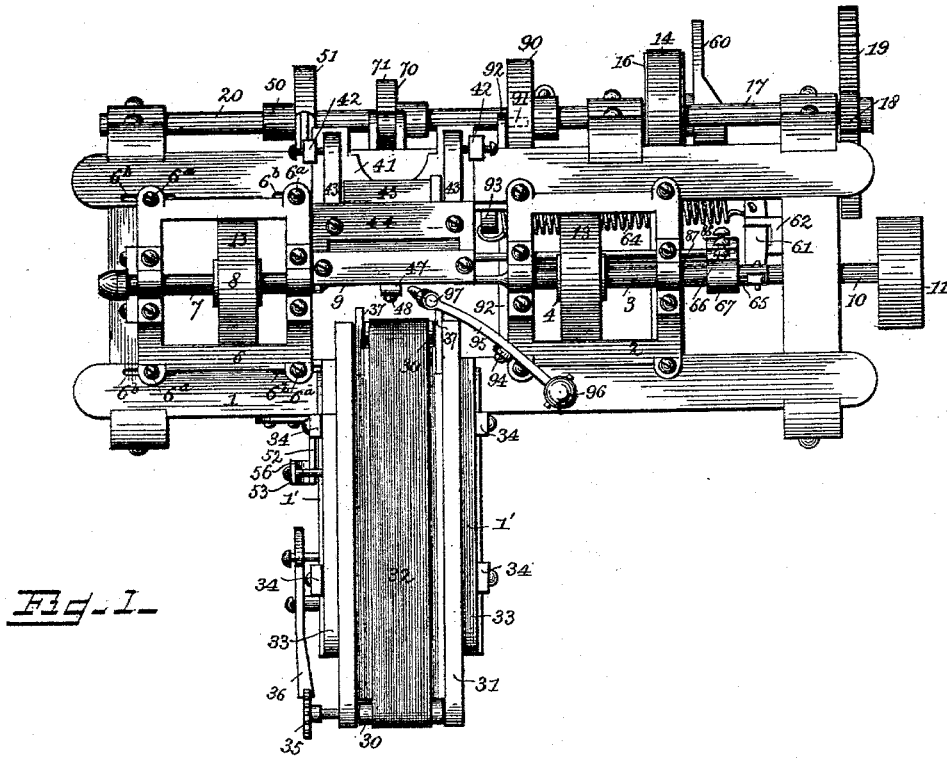

Witnesses

Charles Curand.

Inventor

Mason D. Lear

By his Attorneys,

A. J. Collamer,

C. Snow & Co.

M. D. LEAR.
CLOTHES PIN LATHE.

No. 490,206.

Patented Jan. 17, 1893.

Fig. 2.

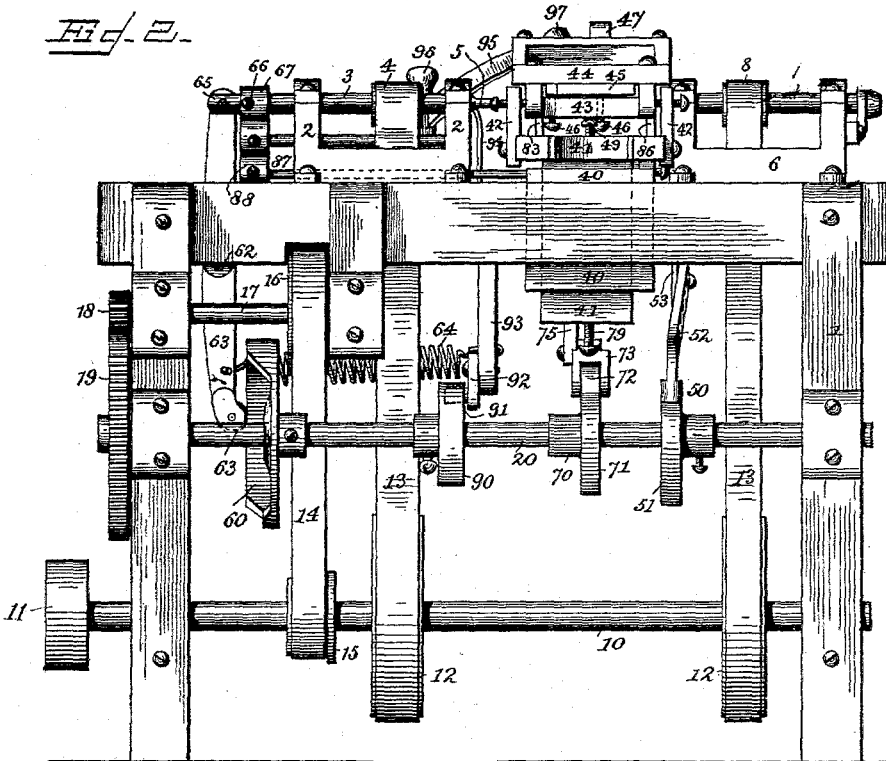
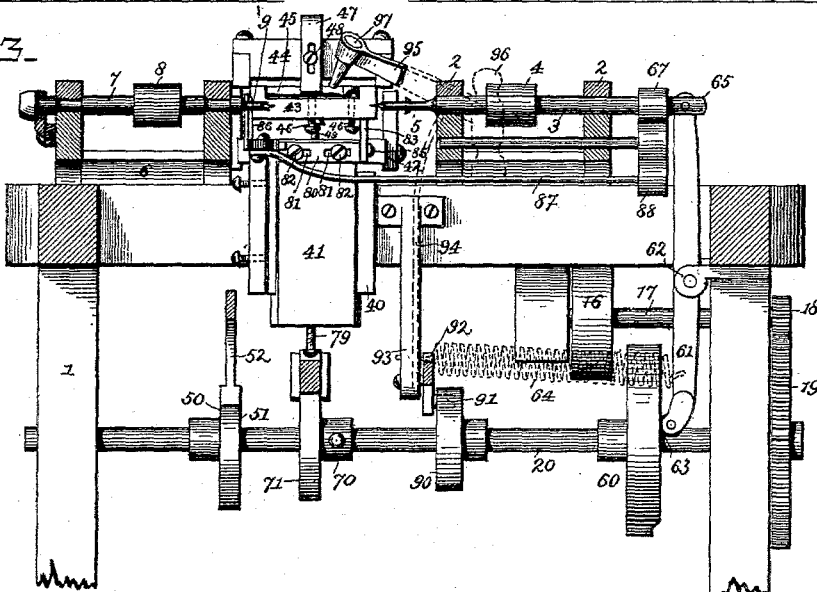

Fig. 3.



Witnesses

Inventor

Cha^s H. Curand.

Mason D. Lear

By his Attorneys,

A. Collamer,

C. Snow & Co.

(No Model.)

4 Sheets—Sheet 3.

M. D. LEAR.
CLOTHES PIN LATHE.

No. 490,206.

Patented Jan. 17, 1893.

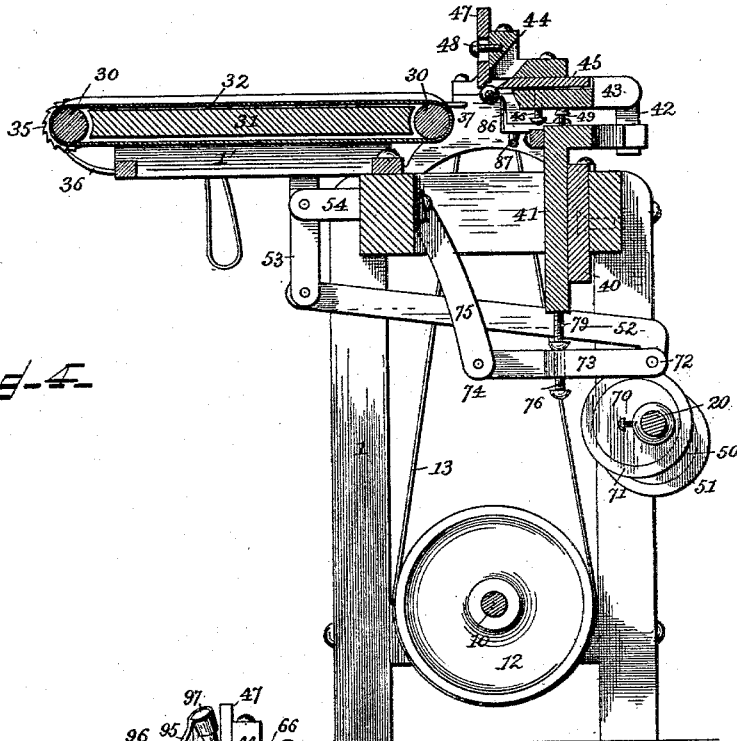

Fig. 4.

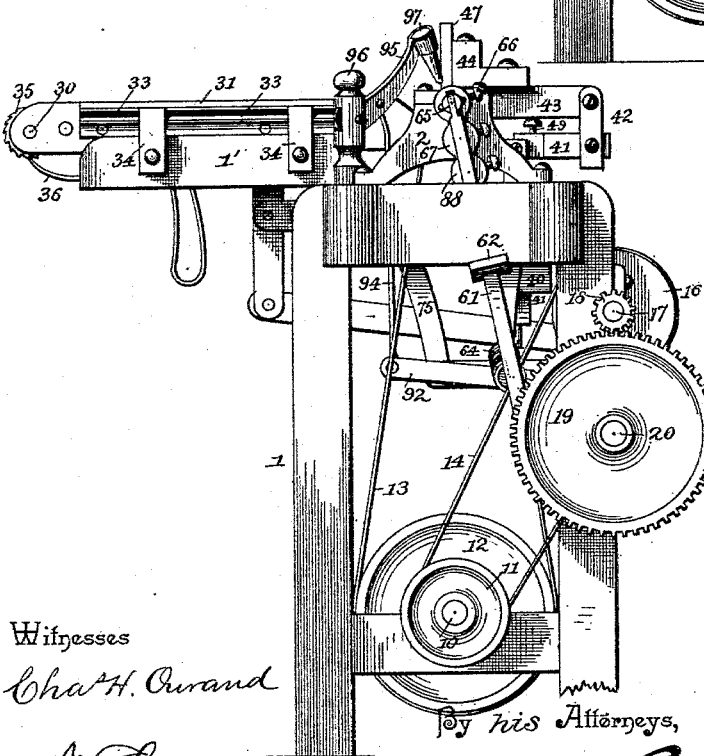

Fig. 5.

Witnesses

Chas. H. Curand

W. Collamer,

Inventor

Mason D. Lear

By his Attorneys,

C. Snow & Co.

(No Model.)

4 Sheets—Sheet 4.

M. D. LEAR.
CLOTHES PIN LATHE.

No. 490,206.

Patented Jan. 17, 1893.

Fig. A.

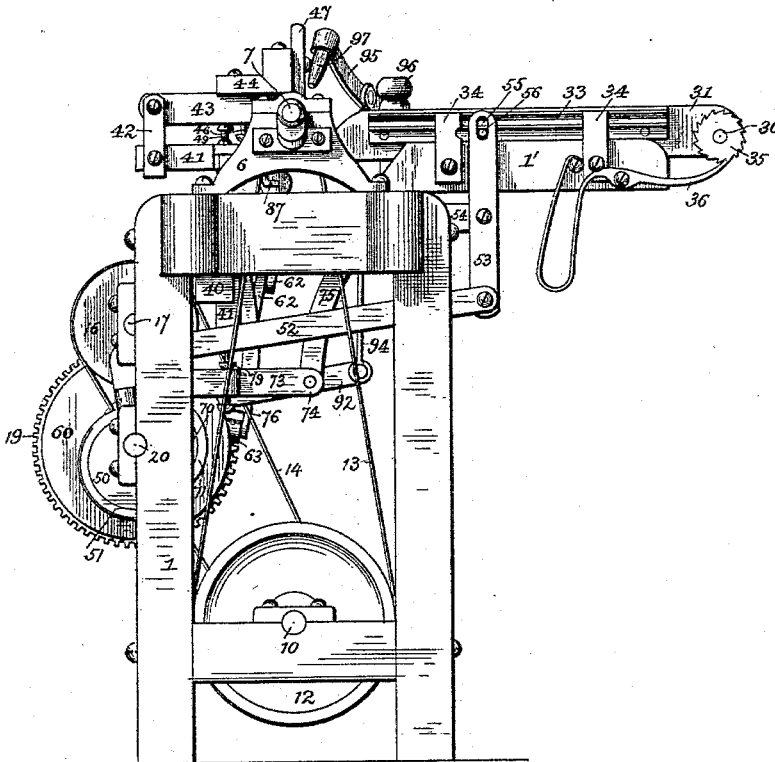
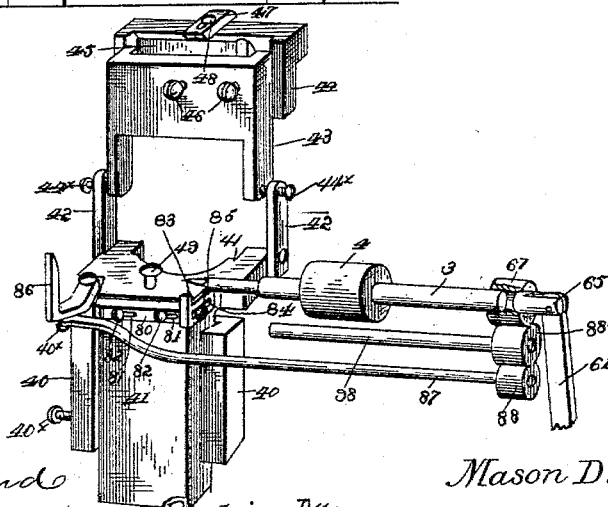

Fig. B.



Witnesses

Chas. H. Curand

M. J. Collamer,

Inventor

Mason D. Lear

By his Attorneys,

Chas. H. Curand

UNITED STATES PATENT OFFICE.

MASON D. LEAR, OF KANE, PENNSYLVANIA.

CLOTHES-PIN LATHE.

SPECIFICATION forming part of Letters Patent No. 490,206, dated January 17, 1893.

Application filed December 4, 1891. Serial No. 414,042. (No model.)

To all whom it may concern:

Be it known that I, MASON D. LEAR, a citizen of the United States, residing at Kane, in the county of McKean and State of Pennsylvania, have invented a new and useful Clothes-Pin Lathe, of which the following is a specification.

This invention relates to lathes, and more especially of that class known as automatic spindle; and the object of the same is to effect certain improvements in machines of this character.

To this end the invention consists in the construction hereinafter more fully described and claimed, and as illustrated on the accompanying four sheets of drawings, wherein—

Figure 1 is a plan view of this machine. Fig. 2 is a rear elevation thereof. Fig. 3 is a central longitudinal section. Fig. 4 is a similar cross section. Figs. 5 and 6 are respectively a left and right end elevation. Fig. 7 is a perspective detail of the cutter removed. Fig. 8 is a detail perspective view broken away in parts showing a portion of the mechanism including the live spindle and the cutter-support and its guide.

Referring to the said drawings, 1 is the main frame-work supporting the various parts of this machine by suitable bearings as will be understood.

2 is a bracket on the top of the framework in which is mounted for reciprocation and rotation the head stock 3 having a small pulley 4, and at the inner end of the stock the live spindle 5; and 6 is a similar bracket in which is mounted for rotation only the tail stock 7 having a small pulley 8, and at the inner end of the stock the dead spindle 9 standing in alignment with the live spindle 5.

10 is the main driving-shaft journaled near the base of the framework and driven by suitable power belted to a driving-pulley 11, and on this shaft are large pulleys 12 connected by belts 13 respectively with the small pulleys 4 and 8. A belt 14 also connects a small pulley 15 on the main shaft with a larger pulley 16 on an idle-shaft 17, and the latter has a pinion 18 on one end which meshes with a large gear 19 on one end of what I shall call the cam-shaft 20.

1' is a horizontal framework extending laterally from the main framework 1, and over

rollers 30 at the ends of the carriage 31 moves an endless apron 32 for feeding the blocks to the lathe. The said carriage has continuous V-grooved or channeled tracks 33 extending the entire length thereof and which move over V-pointed guides 34 mounted in opposite pairs on the horizontal frame whereby the carriage is permitted a free horizontal movement as hereinafter described. On the shaft of the outermost roller 30 is a ratchet-wheel 35, and 36 is a spring-actuated pawl so located as to engage this wheel at each inward movement of the carriage and turn this roller and hence move the apron a slight distance in addition to the movement of the carriage but in the same direction. At the rear or delivery end of the carriage is a pair of fingers 37 projecting slightly beyond the same for a purpose to appear hereinafter.

In a vertical guide 40 of substantial rectangular form having flanges with dove-tail grooves therein and carried by the framework, moves an L-shaped bracket 41 its upper end projecting outwardly over the framework 1 to the rear of the machine, and between ears 42 carried by said upright is adjustably pivoted the body 43 of the cutter, which grooved body has a removable member 44 as shown. The L-shaped bracket 41 has the edges thereof beveled to movably fit the aforesaid guide 40, and the body 43 of the cutter is pivoted between the ears 42 by means of pointed screws 44^x, passing through said ears and having the points thereof engaging recesses in the rear portions of the opposite sides of said body. Extending through one of the flanges of the guide 40, are adjusting screws 40^x, which are adapted to engage the depending portion of the L-shaped bracket 41, and regulate the position thereof and the parts carried thereby relative to the feeding mechanism. Between this removable member and in the grooved portion of the body are located the knives or cutters 45 which are held in place by screws 46 which also serve the purpose of adjusting the knives when desired.

47 is a slotted stop adjustably seated beneath the head of a screw 48 in the face of the member 44, and this stop strikes the stock when the latter has been reduced to the desired size and shape and prevents further cut-

ting thereof by the knives. In the upper end of the bracket 41 is a screw 49 which may be turned in either direction according as it is desired to adjust the angle of the body 43 carrying the member 44 relatively to the bracket and hence all the knives are simultaneously adjusted thereby.

The blocks are put in place for treatment in the following manner: The carriage 31 being piled full of blocks and the machine in operation, the parts are so timed that when the carriage moves forwardly the head stock 3 is retracted, and during the forward movement of the carriage the pawl 36 engages the ratchet 30 and causes the apron 32 to move a sufficient distance to carry the outermost block onto the fingers 37 and in exact alignment with the spindles 5 and 9. At this time the live spindle is driven in a short distance and engages the block on its own and the dead spindle's point, the carriage recedes, and then the live spindle is moved still farther in to embed the prongs of the spindles in the ends of the block and cause it to rotate with them.

The mechanism which causes the movements of the various parts as just described consists of connections between such parts and the cam-shaft 20. 50 is an eccentric on said shaft whose surrounding band 51 is connected by a rod 52 with the lower end of a lever 53 (pivoted at 54 to a bracket projecting from the framework) and slotted at its upper end as at 55, and 56 is a pin in one of the tracks 33 which engages this slot, so that at each revolution of the cam-shaft the carriage is reciprocated. 60 is a disk-shaped wheel mounted on the cam-shaft and having a laterally projecting cam-face around its edge, and 61 is a lever pivoted between its ends as at 62 in the framework and having a roller 63 at its lower end which travels on said cam face and is held against the same by a spring 64. The upper end of this lever is pivotally connected with a pin 65 held by a set-screw 66 in a collar 67 wherein rotates the rear end of the live spindle 5. The said pin 65 is located in the outer side of the collar 67 and is bifurcated in order to receive the upper end of the said lever 61, which is pivotally held therein as set forth and said pin is independent of the said lever. The cam-face on the disk 60 is so shaped that the lever 61 will be twice moved forward, and hence the live spindle 5 will have the movements above described and which serve to properly draw the block from the carriage; and the eccentric and disk are so timed and set upon the cam-shaft that they will properly operate in conjunction with each other. After the block has been put in place and is being rapidly revolved by the spindles, it becomes desirable to lower the cutters so as to bring them into position to treat the block. To this end, 70 is an eccentric mounted on the cam-shaft 20 and to the surrounding band 71 thereof is pivoted at 72 an arm 73 having the other end of the same pivoted at 74 to the lower end of a bracket 75

depending rigidly from the framework. This arm stands in position to engage a screw 79 in the lower end of the L-shaped bracket 41, and for the purpose of permitting further adjustment a screw 76 passes upwardly through the arm 73 at a point to meet the screw 79 as seen in Fig. 4. The eccentric 70 is so timed that as soon as the block begins to revolve the L-shaped bracket 41 commences to descend and by this means the cutters are moved gradually toward the center of the block until the latter has been turned into the shape desired, which shape is of course regulated by the configuration of the cutting edge.

After the block has been turned it becomes desirable that it shall be automatically discharged from position in order to make room for the succeeding block, and this is accomplished in the following manner: Against the front corner of the L-shaped bracket 41 stands a block 80 having slots 81 see Fig. 3 through which pass screws 82 into the bracket, whereby the block is held in position but is permitted an adjustment longitudinally to the machine.

83 is an L-shaped finger that has the body thereof slotted as at 84 and is engaged by a screw 85 which passes into the right end of the block 80, by which means the finger is permitted an adjustment transversely of the machine. The purpose of this finger is to prevent the block being drawn with the live spindle 5 completely to the limit of its movement when it recedes.

86 is a second finger pivoted to the upper end of guide 41 near the dead spindle 9, and 87 is a rod pivotally connected to this finger and extending to a collar 88 rigidly connected with the collar 67 above described.

90 is a cam-wheel mounted on the cam-shaft 20 and whose cam-groove is engaged by a pin 91 in one end of a lever 92 which is pivoted between its ends to a rigid bracket 93. From the other end of this lever rises a rod 94 which is pivoted to a discharge-arm 95, the latter being pivotally mounted at one end in an upright 96 on the main frame and having a finger 97 at its other end.

With the above construction, as the carriage approaches and the live spindle recedes to draw out of the block, the latter strikes the finger 83, which prevents the block being drawn with the spindle, the pivoted finger 86 is moved to push the block at its other end off the dead spindle, and the discharge-arm descends so that its finger 97 strikes the block and pushes it out of place, just in time to permit the next succeeding block to come into position and to be automatically engaged as above described. When the dead spindle wears, its bracket 6 can be adjusted by the screws or bolts 6^a in the slots 6^b.

Between the collars 66 and 88 is another collar 88^x and all of said collars are of integral formation and arranged in alignment, a guide rod 98 is fixed to the collar 88^x by a

set screw 99 and said rod extends endwise through the bracket 2 to provide a rigidity of movement or positive action for the parts working simultaneously therewith and also to steady the movement of said parts. When the spindle 3 recedes, the rod 87 moves backward therewith through the connection of the collars 66 and 88 as set forth, and thereby operates to draw the finger 86 against the end of the work in connection with the dead spindle 9, to disconnect it from the latter and thereby make the release of the completed work attainable in an automatic manner.

What is claimed as new is—

1. In a lathe, the combination of the tail stock, the head stock, means for turning the latter and for reciprocating it at predetermined intervals, a reciprocating carriage arranged at right angles to the line of and between the stocks and carrying an intermittently movable belt, a stationary guide arranged opposite the inner end of the carriage, a vertically movable bracket sliding in said stationary guide, a cutter frame pivoted on top of said bracket and moving therewith, said cutter frame having a groove, cutters adjustably clamped in the grooves of said cutter frame, an L-shaped vertically arranged finger 83, longitudinally and transversely adjustable on the vertically movable bracket and therefore moving therewith, an opposite movable finger connected with the head stock, and a vertically adjustable stop mounted on the front of the pivoted cutter frame and arranged between the two fingers, substantially as set forth.

2. In a lathe, the combination with the frame work and the rotating spindles one of which is longitudinally movable at predetermined intervals; of a vertical stationary guide secured at one side of the frame work between the spindles, a vertically reciprocating L-shaped bracket moving in said stationary guide, a cam shaft having an eccentric, an arm pivoted to the band surrounding the eccentric and pivotally supported by a bracket, an adjusting screw passing through this arm, a screw in the lower end of the bracket loosely resting on the screw in said arm, adjusting screws 40^x, adapted to extend through one side of the stationary guide to regulate the position of the sliding bracket therein, an adjustable cutter frame pivoted on top of said bracket and moving therewith, clearing fingers adjacent to said spindles, one of which

is movable by the reciprocations of one spindle and the other of which is longitudinally and transversely adjustable on said bracket, and a feeding carriage, substantially as set forth.

3. In a lathe, the combination of the tail-stock, the head-stock, means for rotating the latter and for reciprocating it at predetermined intervals, a stationary guide, a vertically adjustable cutter frame mounted in said guide and freely pivoted and carrying cutters, a finger mounted on a horizontal pivot fixed to one side of said guide and having its tip moving adjacent to and longitudinally of the dead spindle, a rod pivotally connecting this finger with the head-stock, and a longitudinally and transversely adjustable finger standing adjacent the live spindle against which finger the block strikes as this spindle is withdrawn, as and for the purpose set forth.

4. In a lathe, the combination of the tail-stock, the head-stock, means for rotating the latter and for reciprocating it at predetermined intervals, a cutter frame carrying cutters, a bracket, a slotted block, screws passing through the slots into the bracket, a finger having a slotted body, the slot standing at right angles to the slots in the block, and a screw passing through this slot into said block, the tip of the finger standing adjacent the live spindle when the latter engages the block, as and for the purpose set forth.

5. In a lathe, the combination with the framework, the rotating spindles, a vertical guide, and an arm swinging in a vertical plane; of a bracket moving in said guide and raised by the movement of said arm, the body of the bracket being L-shaped with its upper horizontal end projecting away from the spindles, ears rising from the outer corners of said end, a cutter frame pivoted between said ears, a screw in the bracket adjustably supporting the cutter, an adjustable stop on the central upper portion of said body of the bracket, and an adjusting screw in the lower part of said bracket resting loosely on said arm, substantially as described.

In testimony that I claim the foregoing as my own I have hereto affixed my signature in the presence of two witnesses.

MASON D. LEAR.

Witnesses:

A. P. HUEY,
WM. FRALEY.